

VOLUME (l)
VOLUMEN (l)

MAX. LOAD (kg)
MAX. BELASTUNG (kg)

FLOOR LOAD (kg/m²)
BODENBELASTUNG (kg/m²)

150

270

250

- - Spot for el. cable 3x2.5mm², length approx. 1m
- Platz Stromkabel 3 x 2,5 mm², Länge cca. 1 m
- - Spot for el. cable 1x6mm² for earthing, length approx. 1.5m
- Platz Stromkabel 1 x 6 mm² für Erdung, Länge cca. 1,5 m
- - Drain spot Ø 50mm
- Abflussplatz Ø 50 mm
- ▨ - Panel - option
- Möglichkeit - Schürze

**INSTALLATION RECOMMENDATION
MONTAGEEMPFEHLUNG**

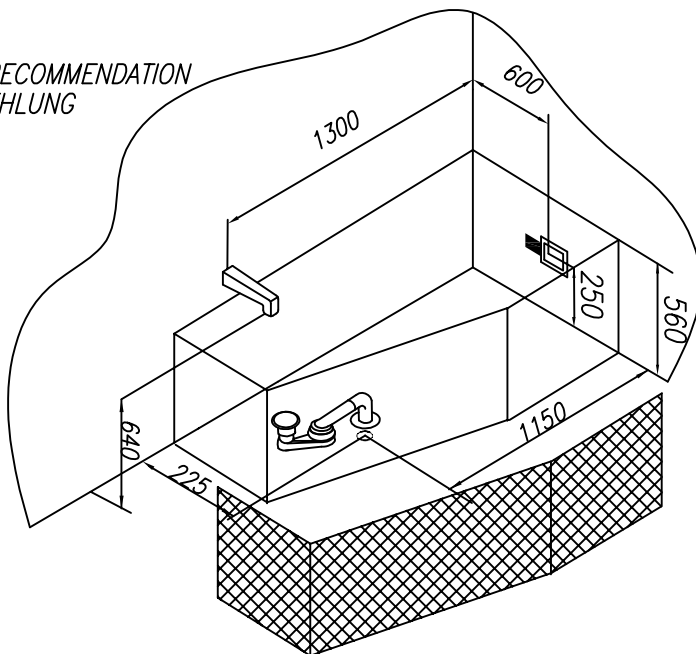

Recommended overflow set Vorgeschlagene Überlaufgarnitur	PAL 450
Recommendations for the installation of bathtub without panel Empfehlungen für die Montage von Badewannen ohne Schürze	Nr. MK 03
Recommendations for the installation of bathtub with panel Empfehlungen für die Montage von Badewannen mit Schürze	Nr. MK 01
Option of the built-in bathtub base Möglichkeit des Sockels für die Badewannen ohne Schürze	Nr. MK 05 PKK 501
Option of the bathtub base with panel Möglichkeit des Sockels für die Badewannen mit Schürze	pre-assembled vormontiert

FIDELIO-L 160x80

POSITION OF SWITCHES AND GENERATORS IN DIFFERENT VERSIONS OF MASSAGE SYSTEMS

POSITION SCHALTER UND AGGREGATE BEI VERSCHIEDENEN AUSFÜHRUNGEN VON MASSAGESYSTEMEN

- | | | | | |
|---|---|---|--|--|
|  - PUMP
- WASSERPUMPE |  - WATER JETS
- WASSERDÜSEN |  - AIR CONTROLLER
- LUFTREGLER |  - ELECTRONIC SWITCHES
- ELEKTROSCHALTER |  - FIXTURE AND SHOWER HANDLE
- WASSERHAHN UND DUSCHE |
|  - BLOWER
- LUFTPUMPE |  - AIR JET
- LUFTDÜSE |  - PNEUMATIC SWITCH
- PNEUMATIKSCHALTER |  - LIGHT OR CHROMOTHERAPY
- LICHT- ODER CHROMOTHERAPIE |  - MICROJET SWITCH
- SCHALTER FÜR MIKRODÜSEN |

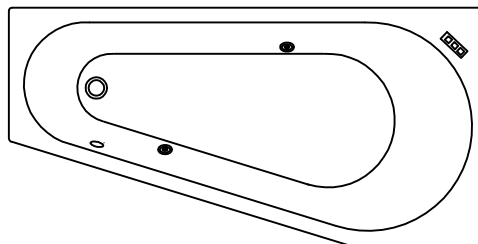
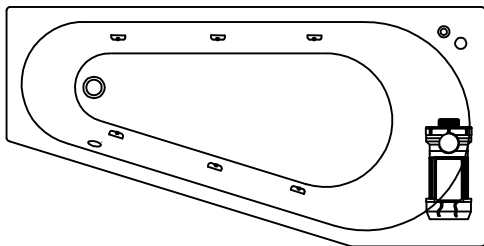

WATER MASSAGE SYSTEM 1 WASSERMASSESYSTEM 1

- PUMP P=800W
- PNEUMATIC SWITCH
- AIR CONTROLLER
- 6 WATER JETS

- WASSERPUMPE P = 800 W
- PNEUMATIKSCHALTER
- LUFTREGLER
- 6 WASSERDÜSEN

- OPTION CHROMOTHERAPY

- MÖGLICHKEIT CHROMOTHERAPIE